

REVISIONS			
REV	DESCRIPTION	DATE	APPROVED

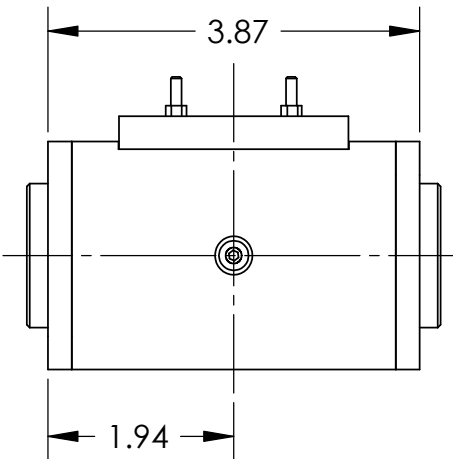
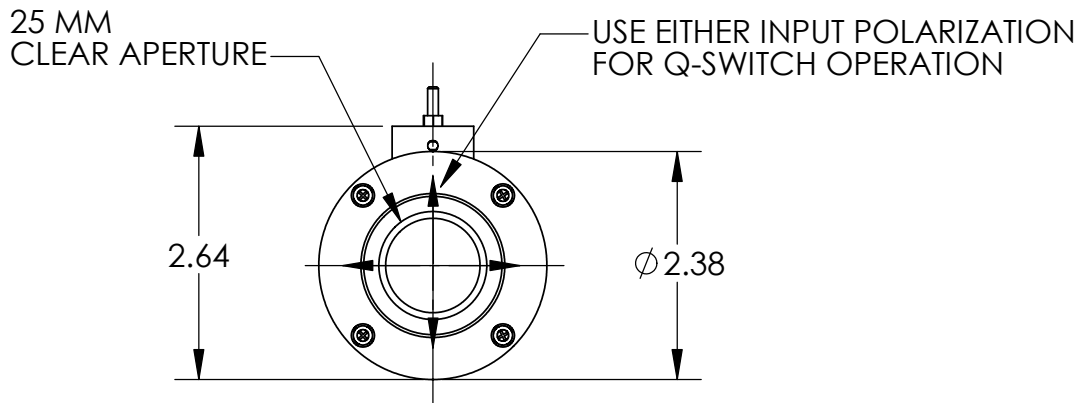
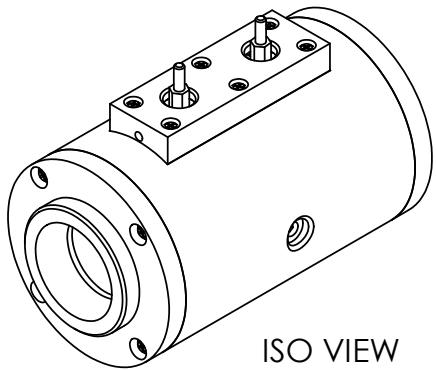
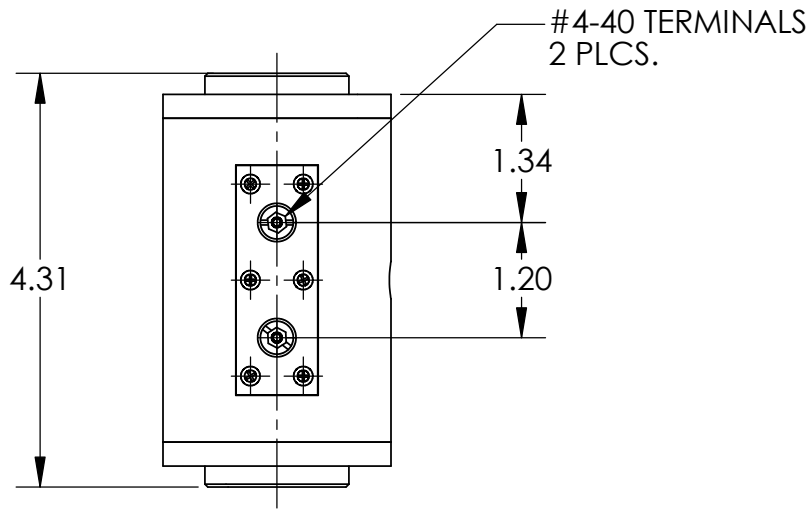

**THIRD ANGLE PROJECTION**

**NOTICE ALL PERSONS RECEIVING THIS DRAWING**

THIS PRINT, AND THE INFORMATION IT GIVES, ARE THE PROPERTY OF INRAD. THE PRINT IS NOT TRANSFERABLE, AND IT AND ANY COPIES ARE TO BE RETURNED UPON THE COMPLETION OF THE CORRESPONDENCE OR ORDER. THE INFORMATION IS GIVEN IN CONFIDENCE FOR A LIMITED PURPOSE, IS NOT TO BE DIVULGED AND IS NOT TO BE USED BEYOND THAT PURPOSE.

UNLESS OTHERWISE SPECIFIED DIMENSIONS ARE IN INCHES

TOLERANCES :

ANGLES: .X ± .015  
.XX ± .010  
0° 30' .XXX ± .005

BREAK ALL SHARP CORNERS UNLESS OTHERWISE NOTED.

**MATERIAL;**

**FINISH;**

USED ON P.L.

DRFT. R. Braescu 08/21/01

CHKR. F. Marsanu 08/21/01

ENG.

REF.

**inrad** NORTHVALE, NEW JERSEY 07647

OUTLINE DRAWING  
M/N: PKC21-25/2  
KD\*P POCKELS CELL

SIZE <b>A</b>	DRAWING NO. <b>6581-2</b>	REV.
SCALE 1:2	SolidWorks2001	SHEET 1 of 1